

Fiber Optic HDTV/SDTV Digital Video Interface Set



The Viper™ system module set for transmitting and receiving all digital video signals—up to 1.5 Gbps

Telecast's TX/RX-292 is a digital video module set that fits inside the Telecast's widely used **Viper** fiber optic system. It offers the industry's broadest range of digital transmission rates while maintaining the quality of transmission that broadcasters demand. The TX/RX-292 supports digital transmission rates from 19.4 Mbps to 1.5 Gbps. The Viper system is your answer to the digital evolution. No matter what your format, the TX/RX292 allows you to implement:

- 19.4 Mbps ATSC
- 34 Mbps E3
- 45 Mbps DS3
- 143 Mbps NTSC composite
- 177 Mbps PAL composite
- 270 Mbps Serial component
- 360 Mbps Serial component video and compressed HDTV
- 540 Mbps proprietary
- 1.2 & 1.5 Gbps HDTV

Standards Compatibility

Because the TX/RX-292 series is format transparent, it can support the transmission of numerous standard interfaces, including applicable SMPTE, ATSC, Bellcore and DVB standards in the range from 19 Mbps to 1.5 gigabits per second. In EQ mode, the TX292 equalizes incoming coaxial cable up to and beyond 360 Mbps.

Part of the Unique Viper Family

Up to 8 modules plug into Telecast's rack mount or portable "Mussel Shell" enclosures. They may be used in conjunction with other modules for multiplexed digital audio, analog audio and auxiliary intercom and high speed data/control communications. Add Telecast's Adder units for a combination of digital video plus up to 64 channels of audio on one fiber.

Features

- Wide range of digital formats
- Compatible with TV standards
SMPTE 292M, 259M & 244M
- 19.4 Mbps to 1.5 Gbps transport
- No pathological data problems
- Equalizes coax up to 540 Mbps
- Up to 22 dB optical link budget
- Low system jitter
- Rack mount or portable
- Miniature plug-in modules
- 8 Channels per 2 RU chassis
- AC or DC operation
- Battery back-up included in Viper
- Wide temperature range
- Low power consumption
- High reliability design
- WDM multiplexing optional

Applications

- Field Production
- Sports
- In building HDTV distribution
- ATSC STL
- HDTV STL
- News Gathering
- Telco last mile and local loop
- CLEC access to IXC POP

Specifications

Video

Transmission Method	Digital
Input Level	800 mV (peak to peak)
Input Impedance	75 Ohms
Output Impedance	75 Ohms
Bit-Error Rate (@ -22 dBm received optical power level)	10^{-12}
Jitter (using pathological data pattern)	less than 0.2 UI
Rise/Fall Times	less than 270 ps

Electro-Optical

Operating wavelength	1300 nm
Link margin	up to 22 dB
Transmitter output power options	-6 dBm (std), -3 dBm, & 0 dBm
Receiver sensitivity	-22 dBm
Recommended Transmission Distance Limit	20 kilometers (12.4 miles)
Optical source	Laser diode
Optical detector	PIN
Fiber type	single mode

Mechanical/Electrical/Environmental

Dimensions (WxLxD)	1.2" x 5" x 2"
Weight (per module)	4 ounces
Video connectors (on enclosure)	BNC
Input Voltage Range (enclosure)	12 to 24 VDC (30 VDC max.)
Power Consumption (per module)	2 watts
Temperature Range	-25° to +55°C
Humidity Range	0 to 95% non-condensing

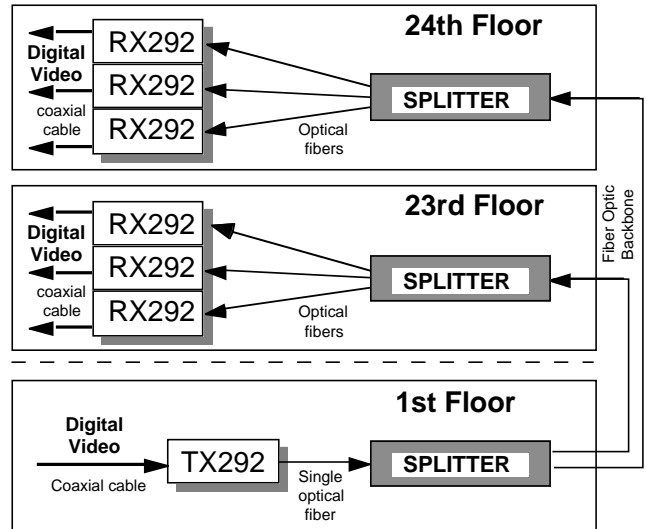

Example of Multipoint Distribution

Because of its wide optical dynamic range, Telecast's TX/RX292 can split its signals several times without degradation

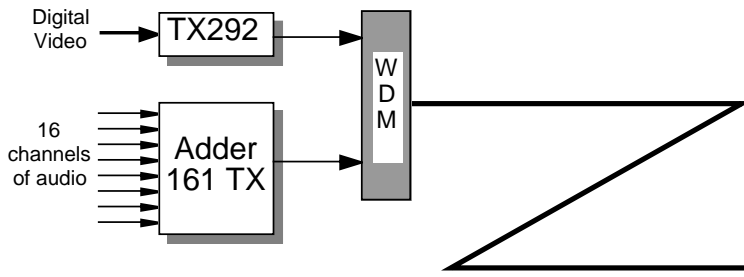

Combining Audio with Digital Video

Optional wavelength-division multiplexers (WDM) combine different wavelengths (colors) of light, transmitting multiple types of signals on one fiber.

Fiber Optic Conductor Compatibility

Fiber Type/Dimensions (Core/Clad)
 • Single mode (8.7/125 μm)
 Recommended Attenuation Factor @ 1300 nm ≤ 0.5 dB/km

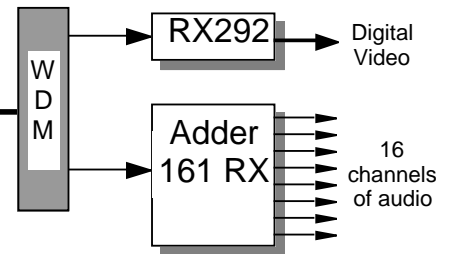

Modules plug into Viper 19" rack frames, like the "442" video/audio/intercom/data chassis (top) or the V800 frame (bottom) which houses up to 8 video channels. Modules also plug into Viper portable Mussel Shell units.



102 Grove Street; Worcester, MA 01605 USA
 Phone: (508)754-4858 FAX: (508)752-1520
 e-mail: sales@telecast-fiber.com
 http://www.telecast-fiber.com